



SC2313LD

四声道音质处理器

一、简介

SC2313LD是一个使用CMOS制程技术的四声道数字音质处理IC。SC2313LD将音量(Volume)、左右声道平衡(balance)高低音质(Treble & Bass)、响度(Loudness)等控制及可选择增益输入(selectable inputgain)内建于单一晶片中,使得SC2313LD具有高效能及高可靠度,且只需运用少许的周边元件,便可达高效率的音质处理功能。SC2313LD的所有功能均可藉由序列总流排(I2C bus)的驱动来达成,并可将其程式化而达多变的的功能。SC2313LD的脚位功能和应用电路是利于作PCB 布局的简易化,并能为相关音响应用节省成本。另外,SC2313LD提供28-pin SO包装,在特性上与TDA7313近似,在脚位上则完全相容。

二、特色

- 简化外部组件
- 高低音控制
- 响度控制
- 可选择3个立体声的增益输入
- 可降低外部噪声的输入/输出系统
- 可前后左右平衡的4个独立扬声器控制
- 独立静音功能
- 音量控制每阶为1.25dB
- 低失真
- 低直流准位漂移
- 可由微处理机序列总线I²C 接口控制

三、应用范围

- 汽车音响
- 立体声音效系统(Hi-Fi Audio System)



SC2313LD

四声道音质处理器

四、 方块图

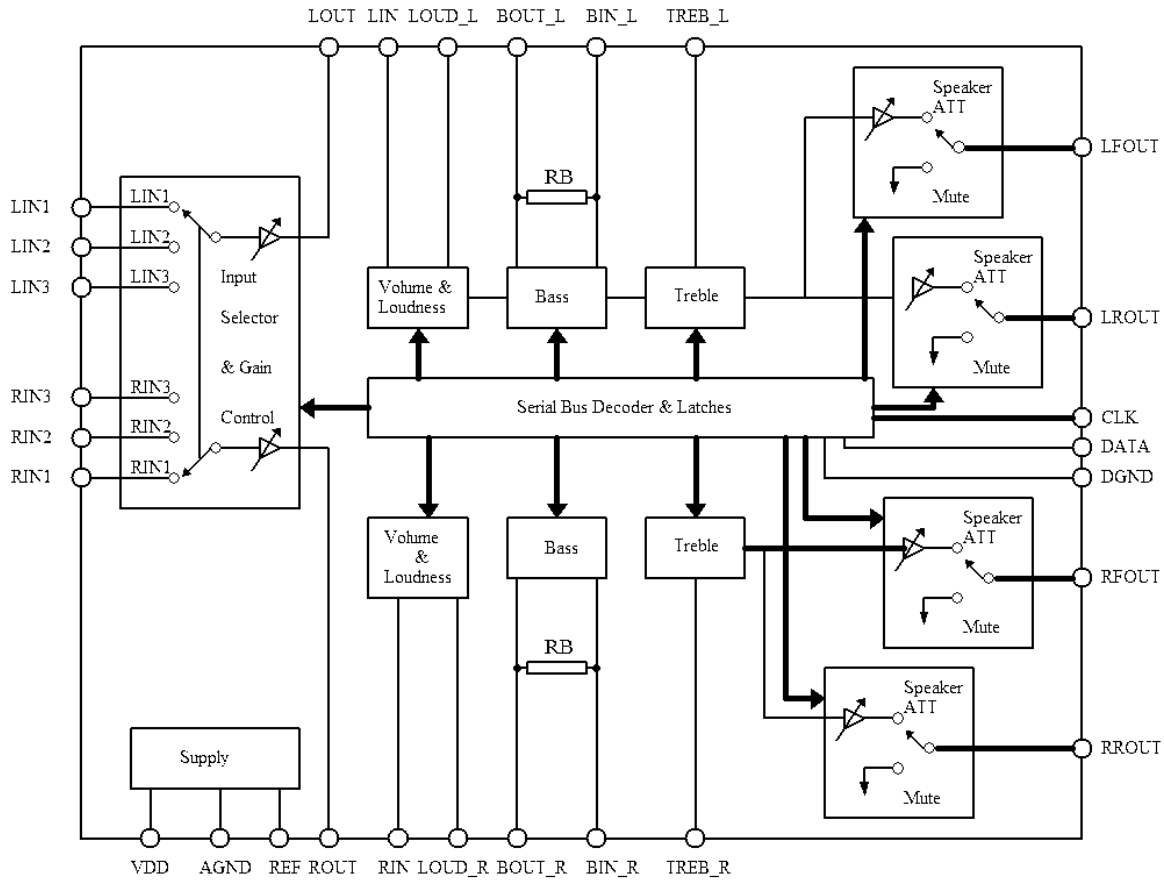

注: SC2313LD (20-pin) 没有规划响度功能 (LOUD_L/LOUD_R) 及音调控制 (TREB_L/TREB_R, BIN_L/BIN_R, BOUT_L/BOUT_R)。

五、 脚位图

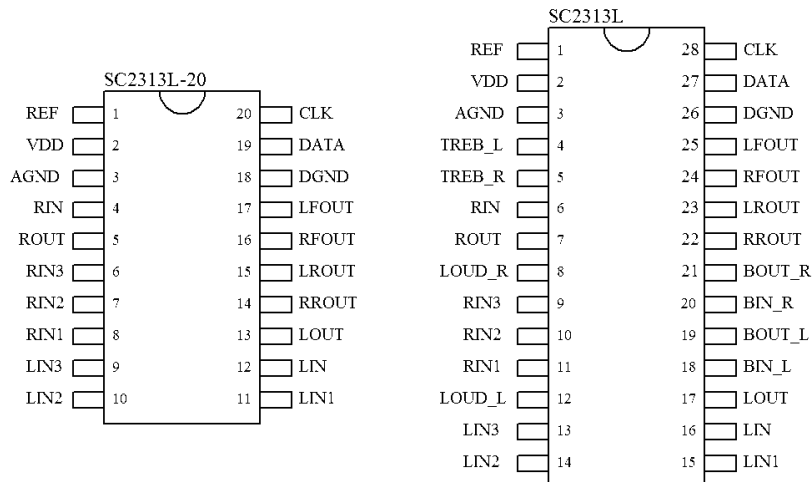



SC2313LD

四声道音质处理器

六、脚位叙述

脚位编号	脚位名称	I/O	叙述
1	REF	-	参考电压(1/2V _{DD})
2	VDD	-	供应电压
3	AGND	-	类比接地
4	TREB_L	I	左声道高音控制
5	TREB_R	I	右声道高音控制
6	RIN	I	右声道音效处理器之输入端
7	ROUT	O	右声道增益输出及输入选择
8	LOUD_R	I	右声道响度控制
9	RIN3	I	右声道音源输入 3
10	RIN2	I	右声道音源输入 2
11	RIN1	I	右声道音源输入 1
12	LOUD_L	I	左声道响度控制
13	LIN3	I	左声道音源输入 3
14	LIN2	I	左声道音源输入 2
15	LIN1	I	左声道音源输入 1
16	LIN	I	左声道输入音质处理
17	LOUT	O	左声道增益输出及输入选择
18	BIN_L	I	左声道低音控制之输出
19	BOUT_L	O	左声道低音控制之输入
20	BIN_R	I	右声道低音控制之输入
21	BOUT_R	O	右声道低音控制之输出
22	RROUT	O	右后声道扬声器输出
23	LROUT	O	左后声道扬声器输出
24	RFOUT	O	右前声道扬声器输出
25	LFOUT	O	左前声道扬声器输出
26	DGND	-	数位接地
27	DATA	I	控制资料输入
28	CLK	I	序列传输的时钟(Clock)输入



SC2313LD

四声道音质处理器

七、序列总线排介面(I²C BUS)功能叙述

序列总线接口(I²C BUS INTERFACE)

藉由使用DATA和CLK总线排，可使SC2313LD与微处理机间做资料的传输。因此，DATA和CLK便构成此序列汇流排介面。

资料确认(DATA VALIDITY)

当CLK讯号是在“高准位”时，DATA Line上的资料才会被视为正确且稳定的资料。而只有当CLK讯号在“低准位”时，DATA Line才可做高、低准位的切换。请参阅下图：

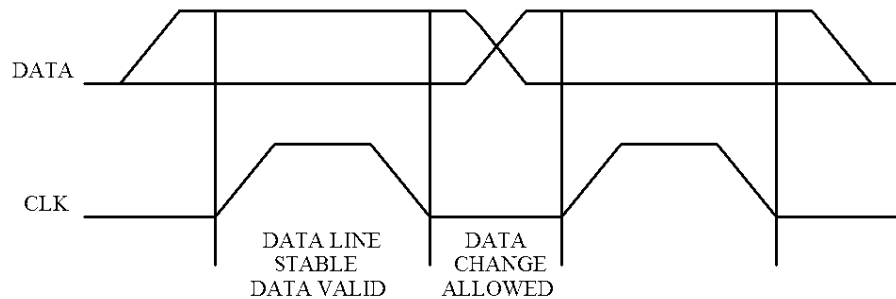

开始和结束(START AND STOP CONDITIONS)

当(1)CLK讯号设定在高准位，且

(2)DATA讯号由高准位转换成低准位时；则表示序列资料的“开始”。

当(1)CLK讯号设定在高准位，且

(2)DATA讯号由低准位转换成高准位时；则表示序列资料的“结束”。请参阅下列时序图：

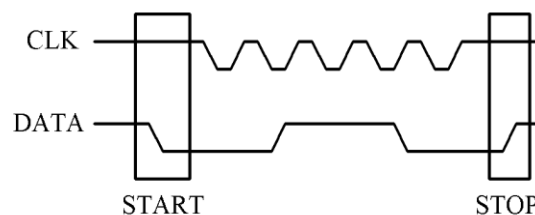

位元组格式(BYTE FORMAT)

每一个传输到DATA Line的字节(byte)有八个位元(bit)，每一位元组后面需有一“认可”位元，且以最大符号位元(MSB)为首的方式传送出去。



SC2313LD

四声道音质处理器

“认可”信号(ACKNOWLEDGE)

在第九个时脉时主体(微处理机)先将DATA Line 设定为电阻性的高准位，若外围设备(SC2313LD)认可此信号，则DATA Line 将会被外围设备(SC2313LD)拉至低准位，使DATA Line 在此时脉中保持一稳定的低准位状态。请参阅下图：

这个已被定址的音质处理器(SC2313LD)在收到每一位元组(BYTE)后，即产生一“认可”的动作；否则在第九个时脉(CLOCK)的时间内Data Line 将会一直保持着高准位状态。

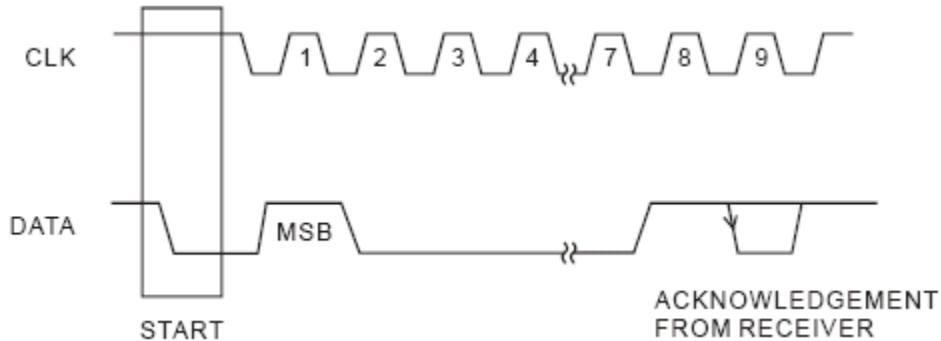

无“认可”信号的传输(TRANSMISSION WITHOUT ACKNOWLEDGE)

如果您想省略此音质处理器(SC2313LD)对“认可”信号的侦测，可使用一较简单的传输方式。其方式为SC2313LD 在收到每一位元组(byte)后，等待一时脉(clock)，不做时脉的确认。如果您使用此种方法，将会有较大的机会造成传输错误，并且会减低对噪声的免疫力。

介面协议(INTERFACE PROTOCOL)

介面协议包含：

1. 起始 (start) 位元
2. 晶片位址位元组=88H
3. ACK=认可位元
4. 资料位元组
5. 结束位元

请参阅下图：

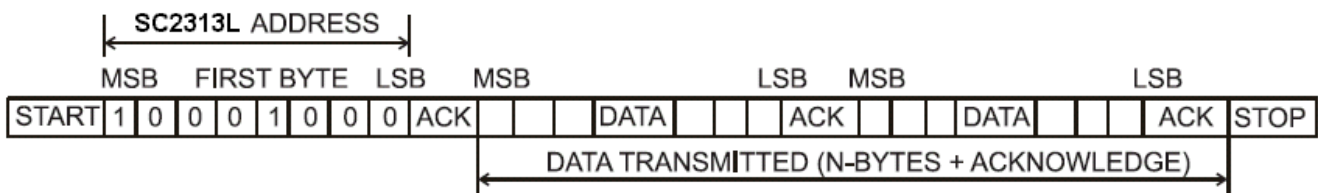

注：ACK=ACKNOWLEDGE

最大时派速度=100K BIT/S



SC2313LD

四声道音质处理器

控制资料 (DATA BYTE) 的格式 (SOFTWARE SPECIFICATION)

SC2313LD位址 (Address):

SC2313LD位址如下所示:

1	0	0	0	1	0	0	0
MSB							LSB

资料位元组 (DATA BYTES)

MSB							LSB	功能
0	0	B2	B1	B0	A2	A1	A0	音量控制
1	1	0	B1	B0	A2	A1	A0	后扬声器的左声道衰减
1	1	1	B1	B0	A2	A1	A0	后扬声器的右声道衰减
1	0	0	B1	B0	A2	A1	A0	前扬声器的左声道衰减
1	0	1	B1	B0	A2	A1	A0	前扬声器的右声道衰减
0	1	0	G1	G0	S2	S1	S0	输入切换/响度/增益控制
0	1	1	0	C3	C2	C1	C0	低音控制
0	1	1	1	C3	C2	C1	C0	高音控制

当 $A_x=1.25\text{dB/step}$; $C_x=2\text{dB/step}$; $G_x=3.75\text{dB/step}$

I²C 总线起始时间

SC2313LD 每次接上电源后,需要等待一段短暂时间以达到稳定,此时间周期与C_{ref} 的数值成正比。在C_{ref}为10 μf 时,至少需等待300mS 后方可对IC 送入I²C 的控制讯号。否则会有控制失效之可能。请参考下图:

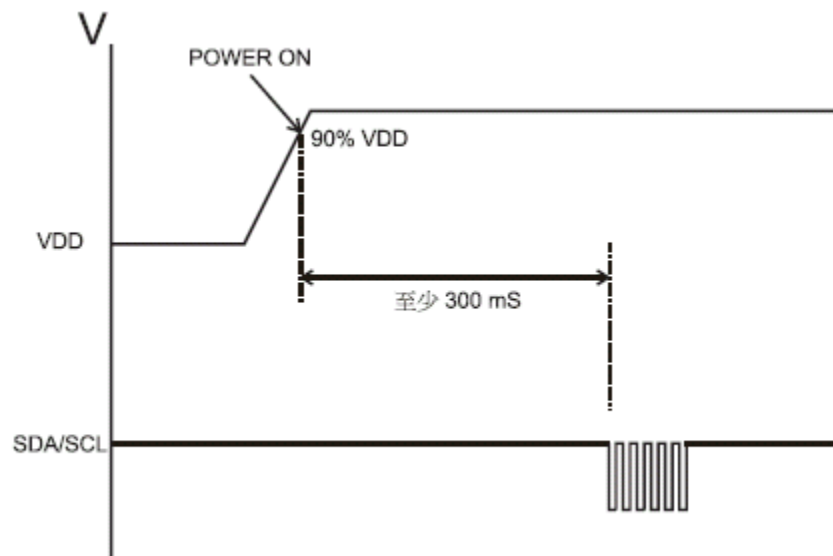



SC2313LD

四声道音质处理器

音量 (VOLUME)

此为一音量的资料位元组之详细叙述表，例如：若音量衰减-37.5dB，则以“00011110”表示之

MSB							LSB	功能
0	0	B2	B1	B0	A2	A1	A0	每阶1.25dB的音量衰减
					0	0	0	0dB
					0	0	1	-1.25dB
					0	1	0	-2.5dB
					0	1	1	-3.75dB
					1	0	0	-5dB
					1	0	1	-6.25dB
					1	1	0	-7.5dB
					1	1	1	-8.75dB
0	0	B2	B1	B0	A2	A1	A0	每阶10dB的音量衰减
		0	0	0				0dB
		0	0	1				-10dB
		0	1	0				-20dB
		0	1	1				-30dB
		1	0	0				-40dB
		1	0	1				-50dB
		1	1	0				-60dB
		1	1	1				-70dB



SC2313LD

四声道音质处理器

扬声器衰减器(SPEAKER ATTENUATORS)

此为一扬声器衰减资料位元组之详细叙述表，例如，若右前声道扬声器衰减30dB，则以"10011000"表示之。

MSB							LSB	功能
1	0	0	B1	B0	A2	A1	A0	左前声道扬声器
1	0	1	B1	B0	A2	A1	A0	右前声道扬声器
1	1	0	B1	B0	A2	A1	A0	左后声道扬声器
1	1	1	B1	B0	A2	A1	A0	右后声道扬声器
					0	0	0	0 dB
					0	0	1	-1.25 dB
					0	1	0	-2.5 dB
					0	1	1	-3.75 dB
					1	0	0	-5 dB
					1	0	1	-6.25 dB
					1	1	0	-7.5 dB
					1	1	1	-8.75 dB
			0	0				0 dB
			0	1				-10 dB
			1	0				-20 dB
			1	1				-30 dB
			1	1	1	1	1	静音

输入切换/响度/增益控制(AUDIO SWITCH DATA BYTE)

此为一输入切换/响度/增益控制的详细叙述表，例如，(SC2313LD，28Pin 版本) 若立体声道1 输入+11.25dB 的增益，并将响度开启，则以"01000000"表示之。

MSB							LSB	功能
0	1	0	G1	G0	S2	S1	S0	音质切换
						0	0	立体声1
						0	1	立体声2
						1	0	立体声3
						1	1	立体声4*1
					0			响度ON*2
					1			响度OFF*2
			0	0				+11.25 dB
			0	1				+7.5 dB
			1	0				+3.75 dB
			1	1				0 dB

- 注：1、立体声4为外接脚位
2、只含在28Pin的版本中



SC2313LD

四声道音质处理器

低音和高音资料位元组 (BASS AND TREBLE DATA BYTES)

此为一低音高音资料位元组的详细叙述表，举例来说，一个-12dB的低音资料位元组，可以“01110001”表示之。

MSB				LSB				功能
0	1	1	0	C3	C2	C1	C0	低音
0	1	1	1	C3	C2	C1	C0	高音
				0	0	0	0	-14 dB
				0	0	0	1	-12 dB
				0	0	1	0	-10 dB
				0	0	1	1	-8 dB
				0	1	0	0	-6 dB
				0	1	0	1	-4 dB
				0	1	1	0	-2 dB
				0	1	1	1	0 dB
				1	1	1	1	0 dB
				1	1	1	0	2 dB
				1	1	0	1	4 dB
				1	1	0	0	6 dB
				1	0	1	1	8 dB
				1	0	1	0	10 dB
				1	0	0	1	12 dB
				1	0	0	0	14 dB

八、大容许规格

符号	参数	额定值	单位
Vs	工作电压	10.5	V
Tamb	工作环境温度	-40 ~ +85	°C
Tstg	储存环境温度	-65 ~ +150	°C



SC2313LD

四声道音质处理器

九、快速参考资料

符号	参数	最小值	标准值	最大值	单位
Vs	供应电压	6	9	10	V
VCL	可处理的最大输入讯号	2	2.5		Vrms
THD	总谐波失真 (V=1Vrms, f=1KHz)		0.07	0.15	%
S/N	讯噪比		95		dB
Sc	声道隔难度 (f=1KHz)		85		dB
	音量控制, 每阶1.25 dB	-75		0	dB
	低音和高音控制, 每阶2dB	-14		+14	dB
	前后左右平衡控制, 每阶1.25dB	-37.5		0	dB
GIN	输入增益, 每阶3.75dB	0		11.25	dB
AMUTE	静音衰减		85		dB

十、电气特性

(除非特别规定, 否则: Tamb=25°C, VDD=9V, RL=100KΩ, Rg=600Ω, 全部无增益《G=0》, f=1KHz)

符号	参数	测试条件	最小值	标准值	最大值	单位
电源供应						
VDD	供应电压		6	9	10	V
Is	供应电流			30	40	mA
输入选择器						
RII	输入阻抗	输入1,2,3	35	50	70	KΩ
VCL	输入最大电压	AV=-8.75dB, d=0.3%	2	2.5		Vrms
SIN	输入隔难度(2)		80	100		dB
GINmin	最小输入增益		-1	0	1	dB
GINmax	最大输入增益			11.25		dB
音量控制						
CRANGE	控制范围		65	70	75	dB
AVMIN	最小衰减值		-1	0	1	dB
AVMAX	最大衰减值		65	70	75	dB
ASTEP	解析度		0.5	1.25	1.75	dB
EA	衰减误差	AV=0 ~ -20dB	-1.25	0	1.25	dB
		AV=-20 ~ -60dB	-3		2	dB
扬声器衰减器						
CRANGE	控制范围		35	37.5	40	dB
SSTEP	解析度		0.5	1.25	1.75	dB
EA	衰减误差				1.5	dB



SC2313LD

四声道音质处理器

AMUTE	输出静音衰减		70	75		dB
低音控制						
Gb	控制范围	最大Boost/Cut	±12	±14	±16	dB
BSTEP	解析度		1	2	3	dB
RB	内部回授阻抗		34	44	58	KΩ

高音控制(1)						
GT	控制范围	最大Boost/Cut	±13	±14	±15	dB
TSTEP	解析度		1	2	3	dB
音质输出						
VOCL	输出最大电压	Av=-8.75Db,d=0.3%	2	2.5		
ROUT	输出阻抗			40	45	
VOUT	直流电压准位		4.2	4.5	4.8	
一般						
NO	输出杂讯	BW=20-20KHz,flat Output mute All Gain=0dB		-97		dB
		A Curve All Gain=0dB		-92		dB
S/N	讯噪比	All Gain=0dB Vo=1Vrms		95		dB
		AV=0,VIN=1Vrms, AV=-8.75dB, IN=1Vrms, AV=-8.75dB, VIN=0.3Vrms		0.1 0.07 0.03	0.33 0.15 0.1	% % %
SC	左/右声道的隔离度		80	90		dB
总线输入						
VIL	输入低电压准位				1	V
VIH	输入高电压准位		3			V
IIN	输入电流		-5		+5	uA
VO	输出电压SDA认可	IO=1.6mA			0.4	V

注：（1）对于低音和高音的响应，请参阅下图，此中心频率和共振点可籍由外部电路去选择。
（2）“选择输入”透过连接一个2.2uF电容器接地。



SC2313LD

四声道音质处理器

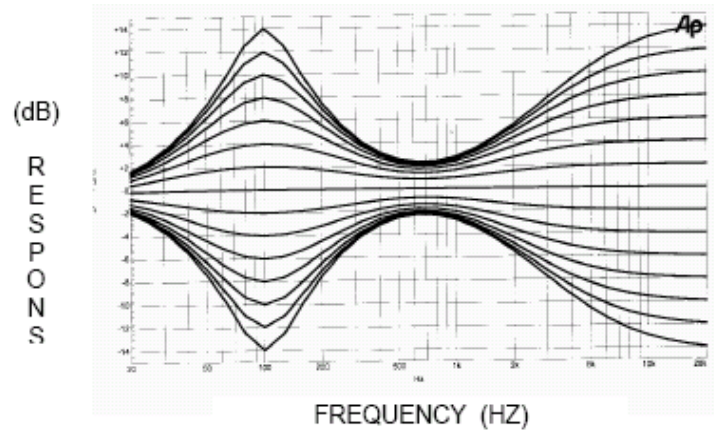

SC2313LD的音质频率响应图

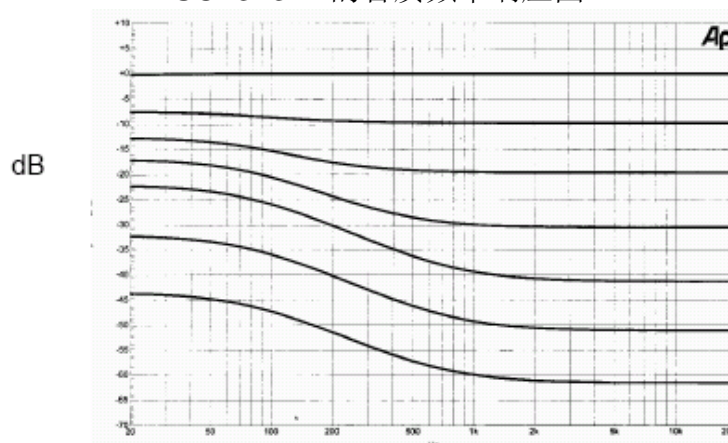

SC2313LD响度于音量衰减频率响应 (C10=C11=100nF)

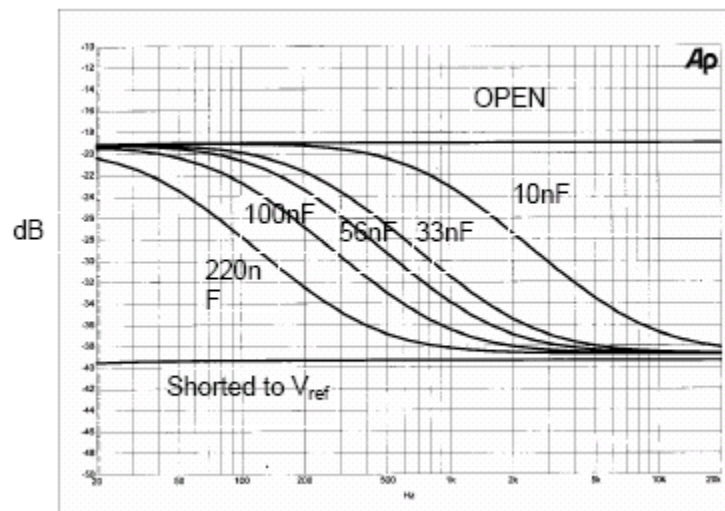

SC2313LD C10、C11对响度的频率响应图 (Volume=-40dB, All other control flat)



SC2313LD

四声道音质处理器

十一、应用电路图

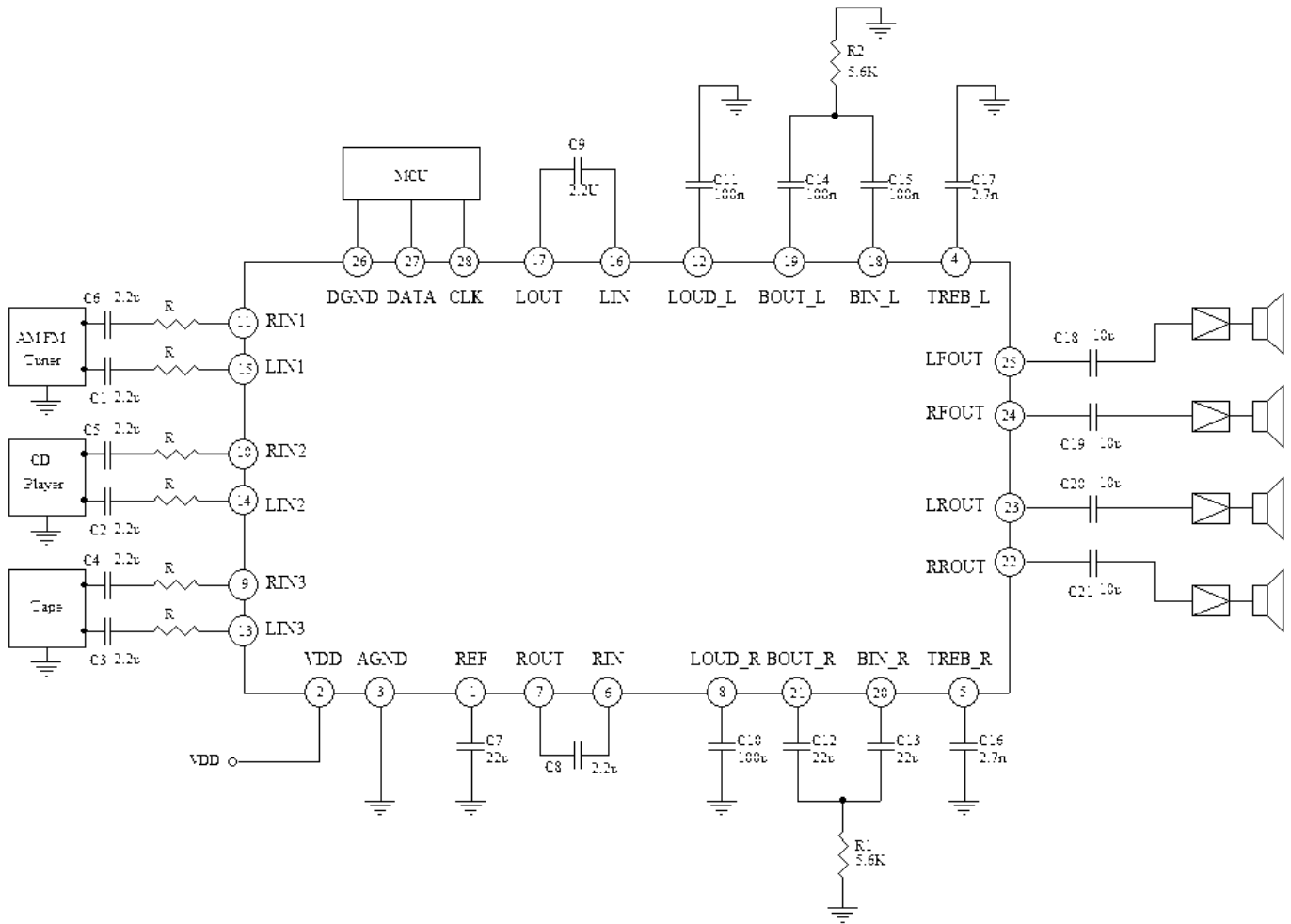

- 注：1. R之范围为2KΩ~3.6KΩ
2. 建议参考值为2.4 KΩ

十一、订购资讯

Valid Part Number	Package Type	Top Code
SC2313LD	28 Pins, SOP(300mil)	SC2313LD
SC2313LD_D	28 Pins, DIP(300mil)	SC2313LD_D
SC2313LD_20	20 Pins, SSOP (150mil)	SC2313LD_20



SC2313LD

四声道音质处理器

十二、包装资讯

28 PINS, SO PACKAGE (300MIL)

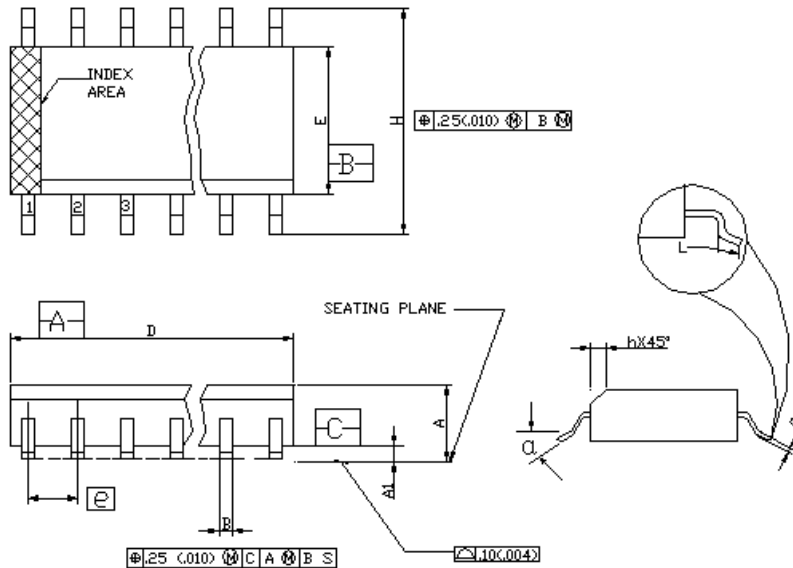

Symbol	Min	Max
A	2.35	2.65
A1	0.10	0.30
B	0.33	0.51
C	0.23	0.32
D	17.70	18.10
E	7.40	7.60
e	1.27 bsc	
H	10.00	10.65
h	0.25	0.75
L	0.40	1.27
α	0°	8°

Notes:

1. Dimensioning and tolerancing per ANSI Y14.5-1982.
2. Dimension D does not include mold flash, protrusions or gate burrs. Mold flash, protrusions and gate burrs shall not exceed 0.15mm (0.006 in) per side.
3. Dimension E does not include interlead flash or protrusions. Interlead flash and protrusion shall not exceed 0.15mm (0.016in) per side.
4. The chamfer on the body is optional. If it is not present, a visual index feature must be located within the crosshatched area.
5. L is the length of terminal for soldering to a substrate.
6. N is the number of terminal positions (N=28).
7. The lead width B as measured 0.36mm (0.014in) or greater above the seating plane, shall not exceed a maximum value of 0.61 mm (0.024 in).
8. Controlling dimension: MILLIMETER
9. Refer to JEDEC MS-013 Variation AE.



SC2313LD

四声道音质处理器

JEDEC is the registered trademark of JEDEC SOLID STATE TECHNOLOGY ASSOCIATION
28 PINS, DI PACKAGE (300 MIL)

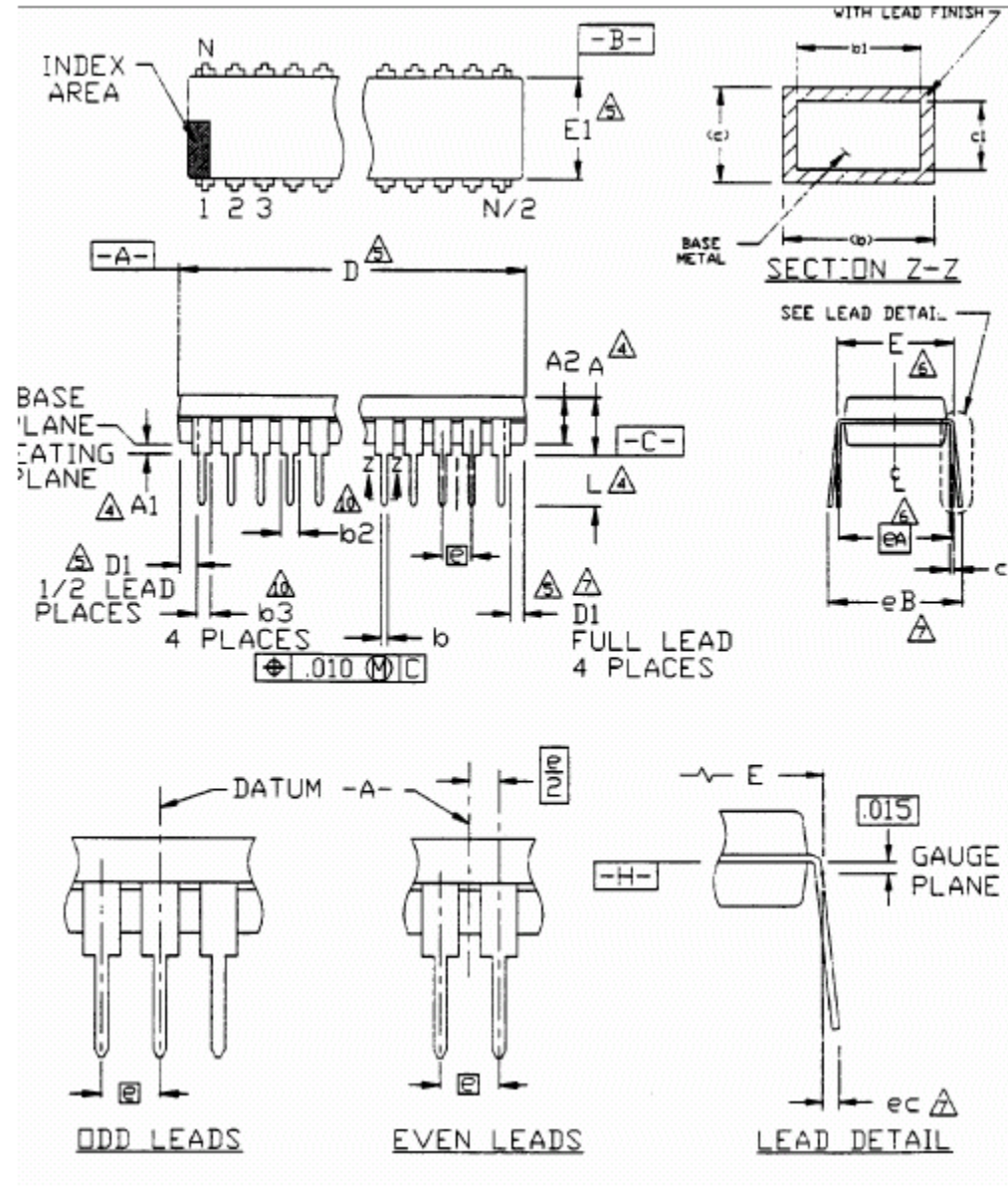



SC2313LD

四声道音质处理器

Symbol	Min.	Nom	Max
A	-	-	0.210
A1	0.015	-	-
A2	0.115	0.130	0.195
b	0.014	0.018	0.022
b1	0.014	0.018	0.020
b2	0.045	0.060	0.070
b3	0.030	0.039	0.045
c	0.008	0.010	0.014
c1	0.008	1.365	0.011
D	1.345	-	1.400
D1	0.005	0.310	-
E	0.300	0.250	0.325
E1	0.240	0.100 BSC	0.280
e	-	0.300 BSC	-
eA	-	-	-
eB	-	-	0.430
eC	0.000	0.130	0.060
L	0.115		0.150

Notes:

1. All dimensions are in INCHES.
2. Dimensioning and tolerancing per ANSI Y14.5M-1982.
3. Dimension A, A1 and L are measured with the package seated in JEDEC Seating Plane Gauge GS-3.
4. D, D1, and E1 dimensions do not include mold flash or protrusions. Mold flash or protrusions shall not exceed 0.010 inch.
5. E and eA measured with the leads constrained to be perpendicular to datum -C- .
6. eB and eC are measured at the lead tips with the leads constrained.
7. N is the number of terminal positions (N=28)
8. Pointed or rounded lead tips are preferred to ease insertion.
9. b2 and b3 maximum dimensions do not include dambar protrusions. Dambar protrusions shall not exceed 0.010" (0.25mm).
10. This variation is a ½ lead package.
11. Distance between leads including dambar protrusions to be 0.005 inch minimum.
12. Datum plane -H- coincident with the bottom of lead where lead exits body.
13. Refer to JEDEC MS-001 Variation BF.

JEDEC is the registered trademark of JEDEC SOLID STATE TECHNOLOGY ASSOCIATION



SC2313LD

四声道音质处理器

20 PINS, SSO PACKAGE (150MIL)

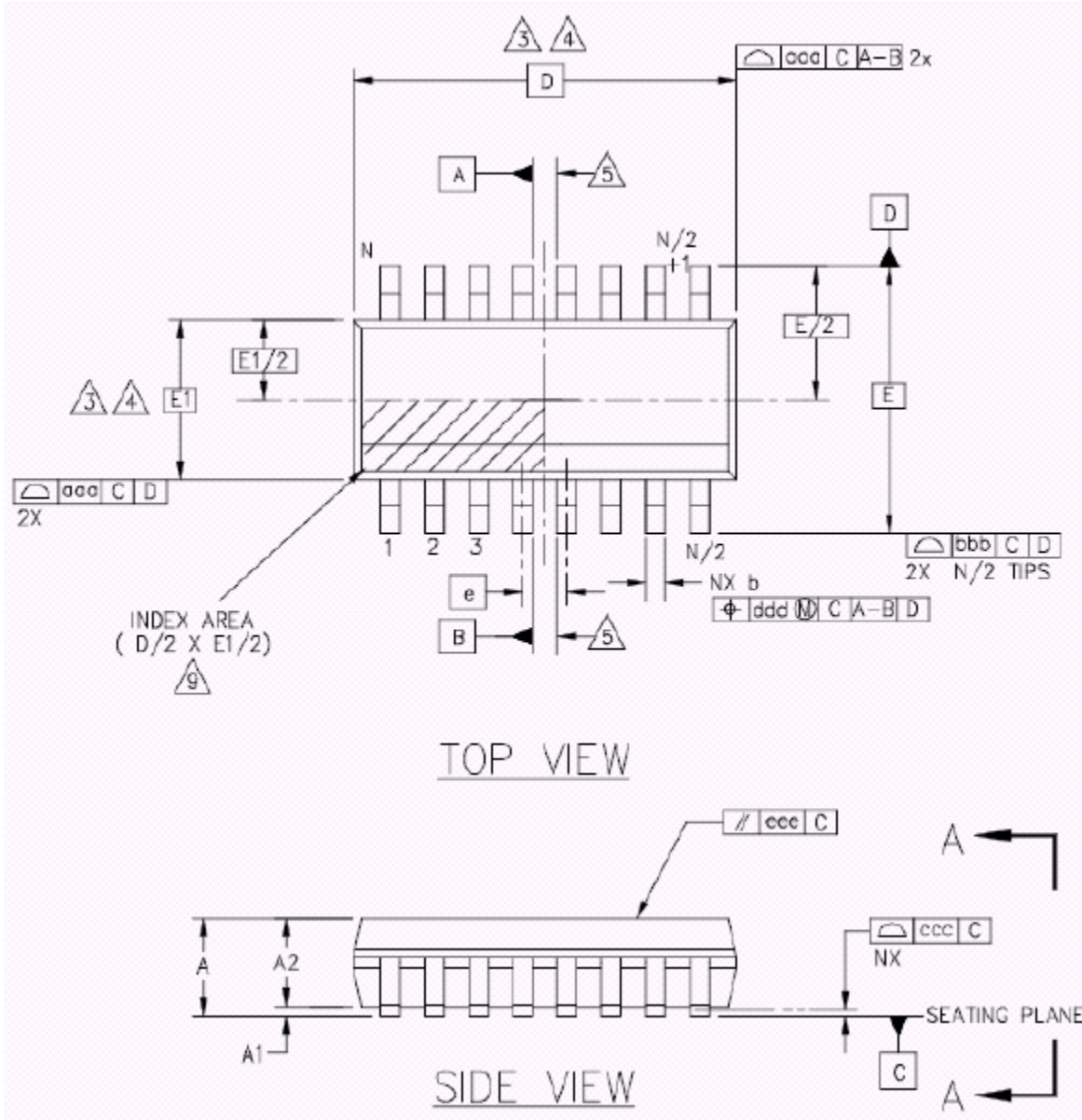



SC2313LD

四声道音质处理器

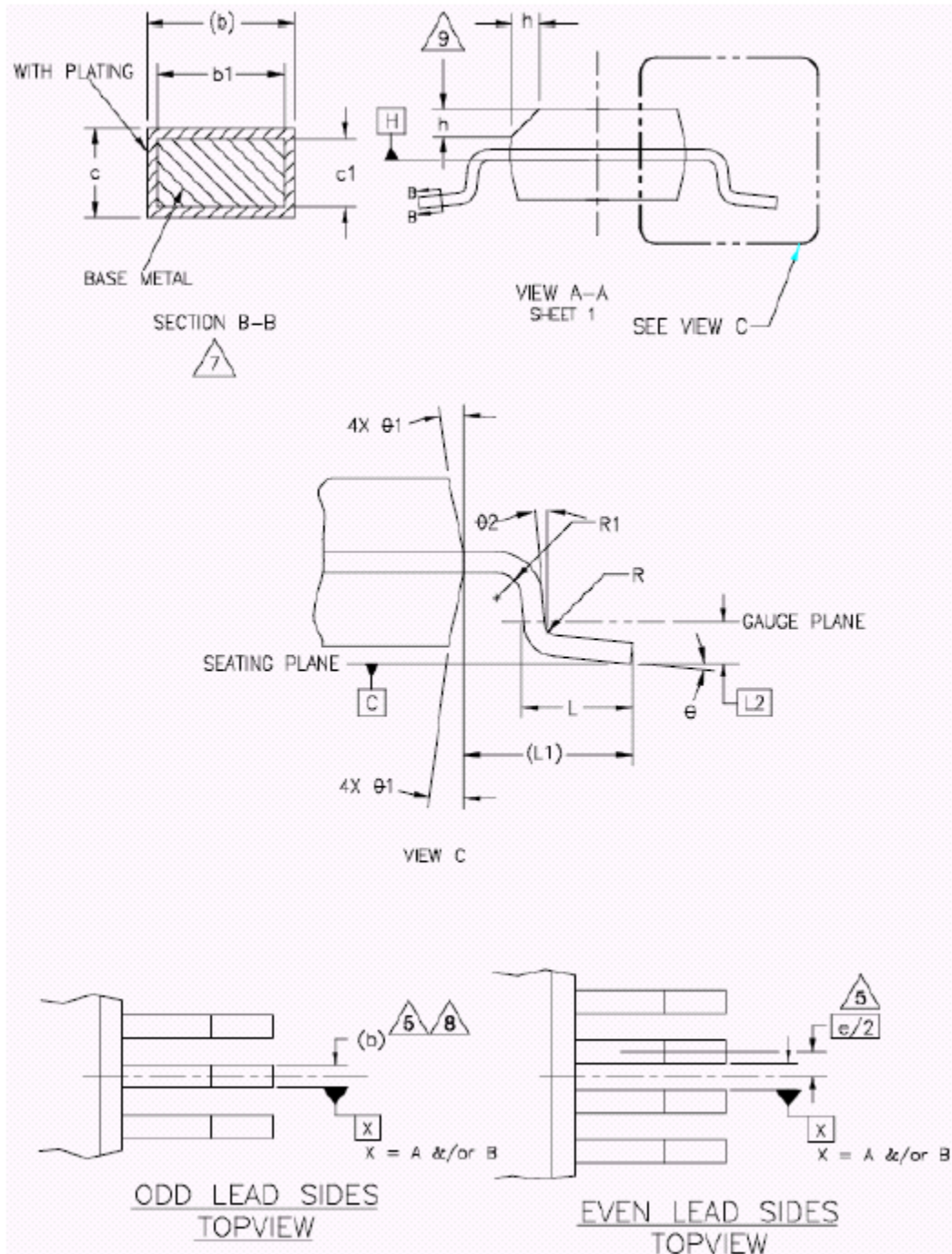



SC2313LD

四声道音质处理器

Symbol	Min.	Nom.	Max
A	0.053	-	0.069
A1	0.004	-	0.010
A2	0.049	-	0.065
b	0.008	-	0.012
b1	0.008	0.010	0.011
c	0.006	-	0.010
c1	0.006	0.008	0.009
D	0.341 BSC		
E	0.236 BSC		
E1	0.154 BSC		
e	0.025 BAS		
L	0.016	-	0.050
L1	0.041 REF		
L2	0.010 BAS		
R	0.003	-	-
R1	0.003	-	-
θ	0°	-	8°
$\theta 1$	5°	-	15°
$\theta 2$	0°	-	-
aaa	0.004		
bbb	0.008		
ccc	0.004		
ddd	0.007		
eee	0.004		

Notes:

1. Dimensioning and tolerancing per ANSI Y14.5M-1982.
2. Dimensions in inches (angles in degrees)
3. Dimension D does not include mold flash, protrusions or gate burrs. Mold flash, protrusions or gate burrs shall not exceed 0.006" per end. Dimension E1 does not include interlead flash or protrusions. Interlead flash or protrusions shall not exceed "0.006" per side. D1 and E1 dimensions are determined at datum H.
4. The package top may be smaller than the package bottom. Dimensions D and E1 are determined at the outermost extremes of the plastic body exclusive of mold flash, tie bar burrs, gate burrs and interlead flash, but including any mismatch between the top and bottom of the plastic.
5. Datums A and B to be determined at datum H.
6. N is the maximum number of terminal position. (N=20)
7. The dimensions apply to the flat section of the lead between 0.004 to 0.010 inches from the lead tip.
8. Dimension b does not include dambar protrusion. Allowable dambar protrusion shall be 0.004" total in excess of b dimension at maximum material condition. The dambar can not be located on the lower radius of the foot.
9. Refer to JEDEC MO-137 variation AD.

JEDEC is the registered trademark of JEDEC SOLID STATE TECHNOLOGY ASSOCIATION